

FOOT PEGS

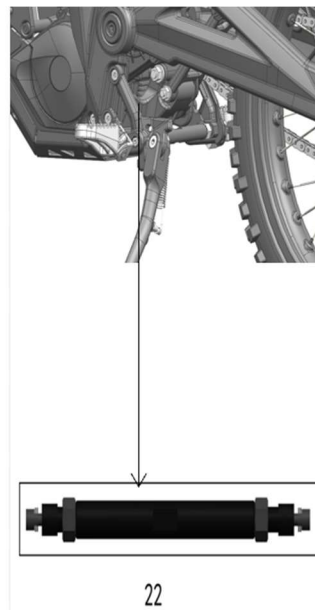
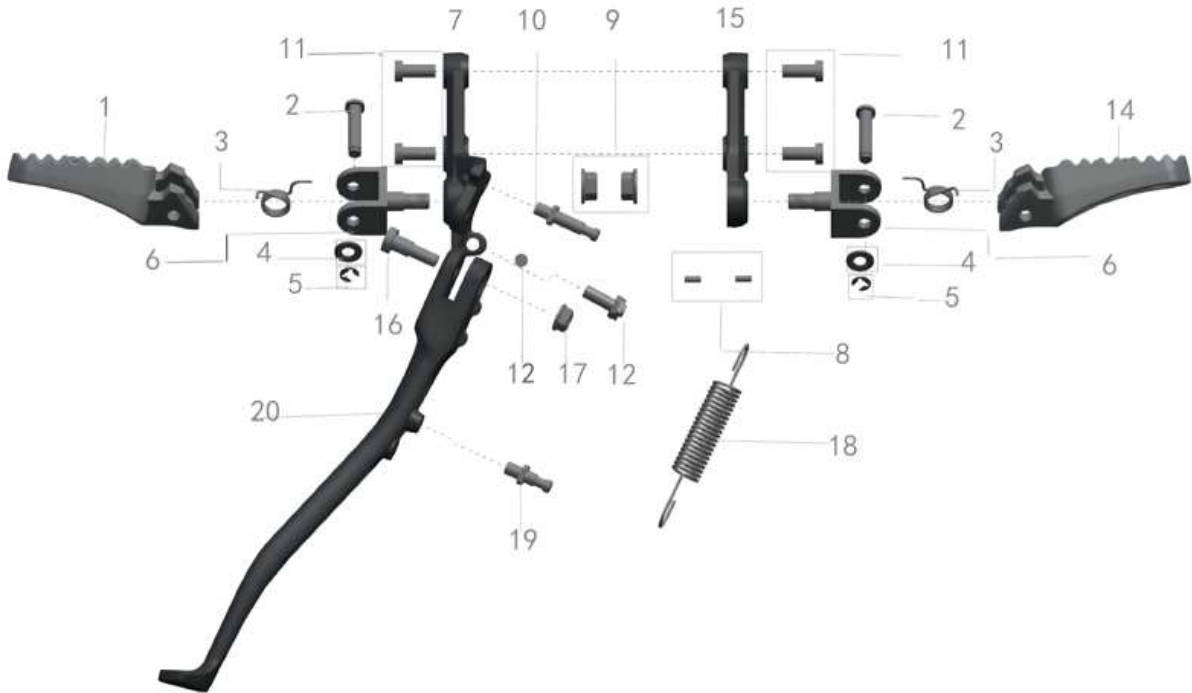

FOOT PEGS

Item	Parte Ref. No.	Descripción	Unit	Qty.	Precio (CLP)
1	40620-56000-000	L. Footpeg	Pcs	1	\$ 20.400
2	43644-56000-000	Footpeg Fixing Pin	Pcs	2	\$ 3.800
3	11802-56000-000	Footpeg Return Spring	Pcs	2	\$ 2.500
4	10724-56000-000	Washer (Φ8*Φ18*1.5)	Pcs	2	\$ 1.500
5	10782-56000-000	Circlip (inner diameter Φ6)	Pcs	2	\$ 1.500
6	40622-56000-000	Footpeg connector	Pcs	2	\$ 9.500
7	40620-56000-000	L. Footpeg Holder	Pcs	1	\$ 18.500
8	43643-56000-000	Pin (Φ4*10)	Pcs	4	\$ 3.800
9	10044-56000-000	Nut GB/T6187.1 (M10*1.25)	Pcs	2	\$ 1.500
10	40327-56000-000	Side Kickstand Spring Pin A	Pcs	1	\$ 5.000
11	10525-56000-000	Screw DIN (M8*25)	Pcs	4	\$ 1.500
12	50200-56000-000	Side Kickstand Power-Off Switch	Set	1	\$ 10.500
13	40621-5600Z-000	L. Footrest Assy.	Set	1	\$ 40.500
14	40640-56000-000	R. Footpeg	Pcs	1	\$ 20.400
15	40642-56000-000	R. Footpeg Holder	Pcs	1	\$ 18.500
16	40324-56000-000	Screw (M8*30)	Pcs	1	\$ 5.000
17	10043-56000-000	Nut GB/T6187.1 (M8)	Pcs	1	\$ 1.500
18	11401-56000-000	Side Kickstand Spring	Pcs	1	\$ 2.500
19	40328-56000-000	Side Kickstand Spring Pin B	Pcs	1	\$ 5.000
20	40320-56001-000	Side Kickstand	Pcs	1	\$ 20.000
21	40640-5600Z-000	R. Footrest Assy.	Set	1	\$ 40.500
22	40650-56000-000	Braces	Set	1	\$ 20.000